

MATERIAL PRODUCIDO GRUPO DE TRABAJO:

**“EL CURRÍCULO BILÍNGÜE DE CIENCIAS NATURALES
PARA EL CURSO DE 1º ESO”**

CURSO 2007-2008

CENTRO DE PROFESORES DE ALCALÁ DE GUADAIRA

Elaborado por:

José Ramón del Pino Ruiz

Eloísa Morillo González

M^a Águila Morillo González

Marina Vyeites Oliva

Rosario Moreno Cazorla

Esther Pueyo Álamo

Estrella Rangel Sánchez

María Manuela González Pinto

M^a Mercedes Bautista Arnedo

Fco José Martínez Ruiz

Content Table

1. THE UNIVERSE AND THE SOLAR SYSTEM.....	5
ACTIVITIES.....	5
GAMES AND INTERACTIVES.....	17
2. THE EARTH AND ITS MOVEMENTS	21
ACTIVITIES.....	21
GAMES AND INTERACTIVES.....	32
3. PROPERTIES OF MATTER.....	37
ACTIVITIES.....	37
GAMES AND INTERACTIVES.....	45

1. THE UNIVERSE AND THE SOLAR SYSTEM

ACTIVITIES

1) Colour the International Space Station.



2) **What's your name? Are you?** Name your Shuttle crew for the mission

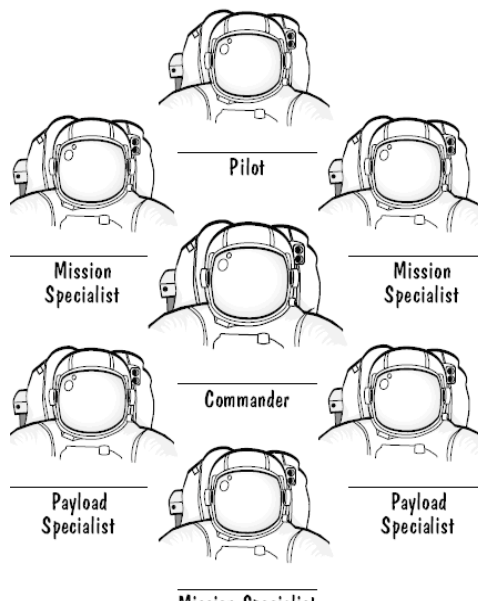

3) Connect the dots on the Shuttle.

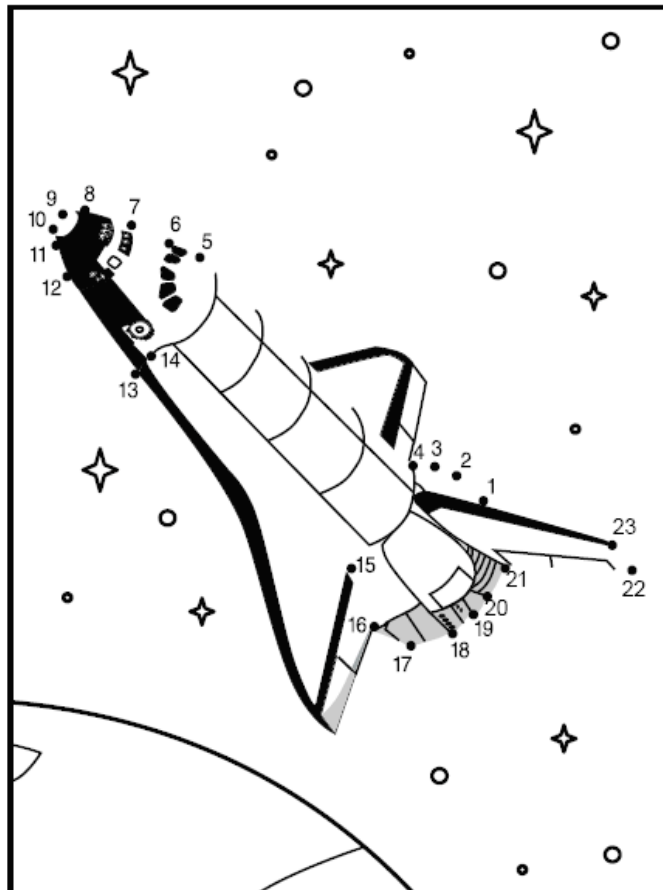

4) Connect the dots on the International Space Station.

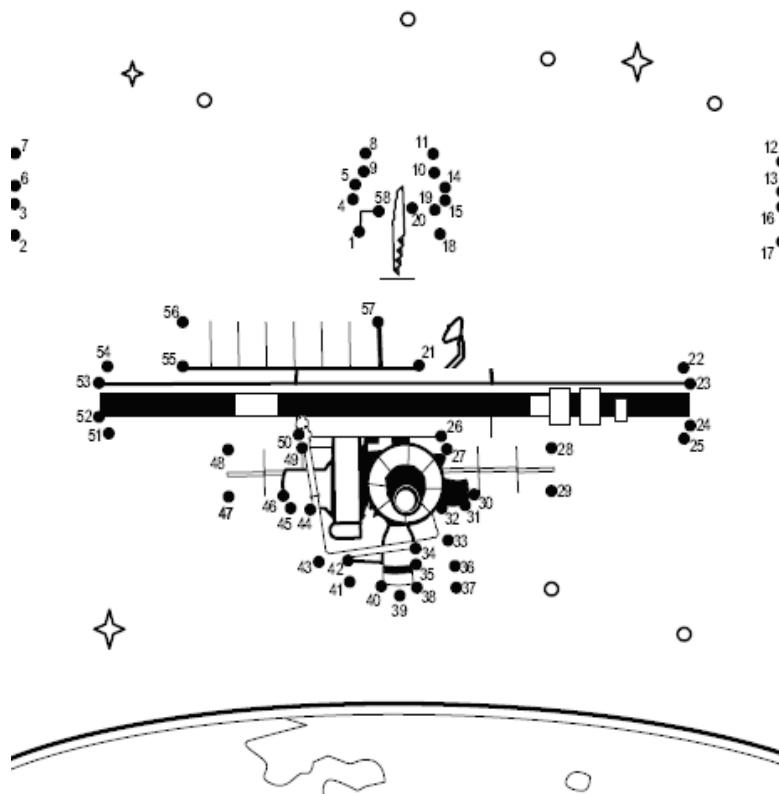

5) **Connect the dots to find the constellation Orion (the hunter).** Orion, also known as "The Hunter," is a constellation in the Northern Hemisphere.

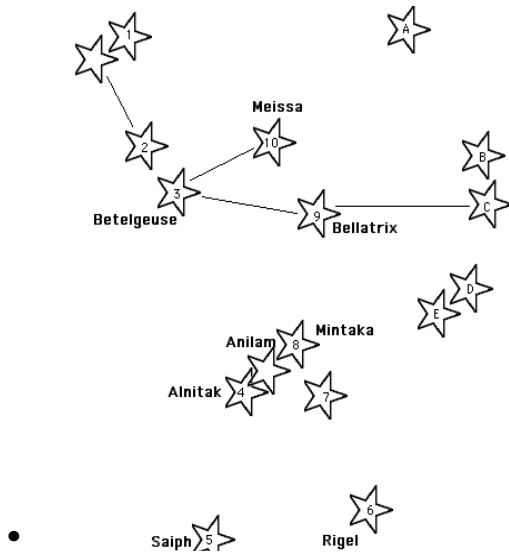

6) **Connect the dots to find the "The Great Bear"**

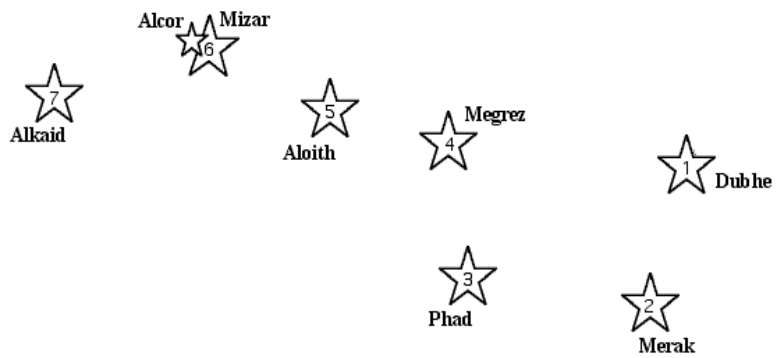

7) **Connect the dots to find the the "scorpion".**

Scorpius (the Scorpio) is a constellation of the zodiac. Connect the dots and see if you can imagine a Scorpio. The brightest star in Scorpius is Antares, a red supergiant star.

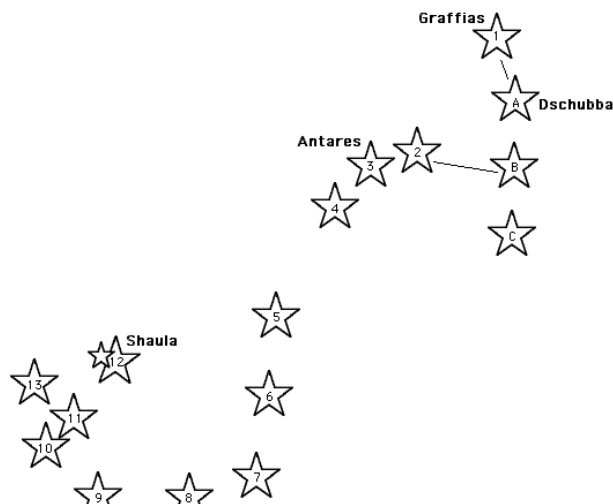

8) What do you remember? Choose the right option.

You already know about

- How the Moon orbits the Earth
- All the things that make up the Solar System

a) The Earth is ...

- flat
- an asteroid
- a planet
- a star

b) The Moon is ...

- an asteroid
- a planet
- a satellite
- made of cheese

c) What force keeps us on the Earth?

- Atmospheric pressure
- Glue
- Magnetism
- Gravity

d) Space is full of ...

- Air
- Alien life-forms
- Gas
- Nothing

9) Choose the right option.

a) Which word means "Sun-centred"?

- egocentric
- geocentric
- heliocentric
- solarcentric

b) An object which orbits another object is called a...

- bung
- moon
- satellite
- spacecraft

10) Filling. Orbiting around “TO ORBIT & TO SPIN”.

- The planets the Sun, the Moon orbits the Earth.
- The Earthon its axis.

11) Color the Solar System.

The Solar System

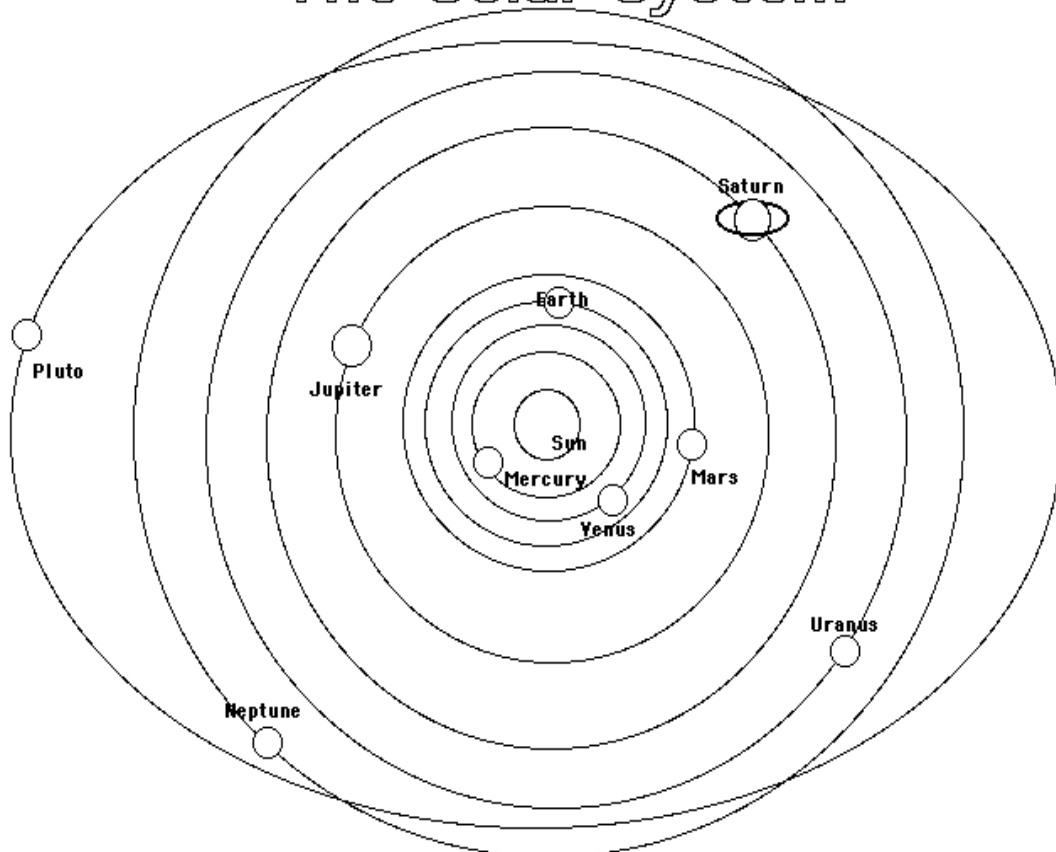

In our **Solar System**, nine planets (Mercury, Venus, Earth, Mars, Jupiter, Saturn, Uranus, Neptune, and Pluto), over 61 moons, many asteroids (mostly in a belt between

12) Think about and answer the question.

- a) What are the main differences between the Sun and the planets? Tick (☑) the correct answers.
- The Sun orbits the planets
 - The Sun produces light, but planets do not.
 - Planets move, but stars don't.
- b) How many planets are there in the Solar System?
- c) What are the two movements the planets make?
- d) What are the names of the planets in the Solar System? Make a list of the planets, starting with the planet closest to the Sun.

13) Colour the “Asteroid Belt”. Read the text slowly and answer.

<<Asteroids are rocky objects that move around the Sun. They are smaller than planets and moons. Most asteroids are located between Mars and Jupiter.>>

a) What are asteroids?

The Asteroid Belt

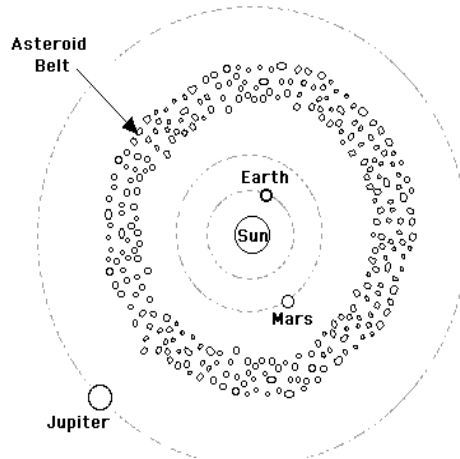

b) Where are asteroids located in the Solar System?

14) Colour the Inner Planets.

The inner planets are those planets that orbit close to the sun. They are: Mercury, Venus, Earth, and Mars. They are relatively small, and are composed mostly of rock. Mercury and Venus have no moons; the Earth has one moon, and Mars has two tiny moons.

The Inner Planets

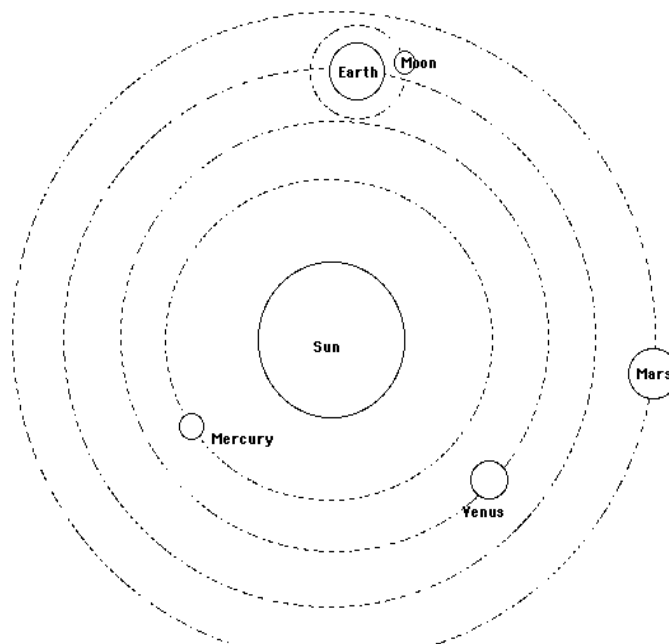

15) Colour the Outer Planets.

The outer planets are those planets that orbit far from the Sun. They are: Jupiter, Saturn, Uranus, Neptune, and Pluto. They are mostly huge, mostly gaseous, ringed, and have many moons (the exception is Pluto which is small and rocky, has one moon, and it considered to be a dwarf planet).

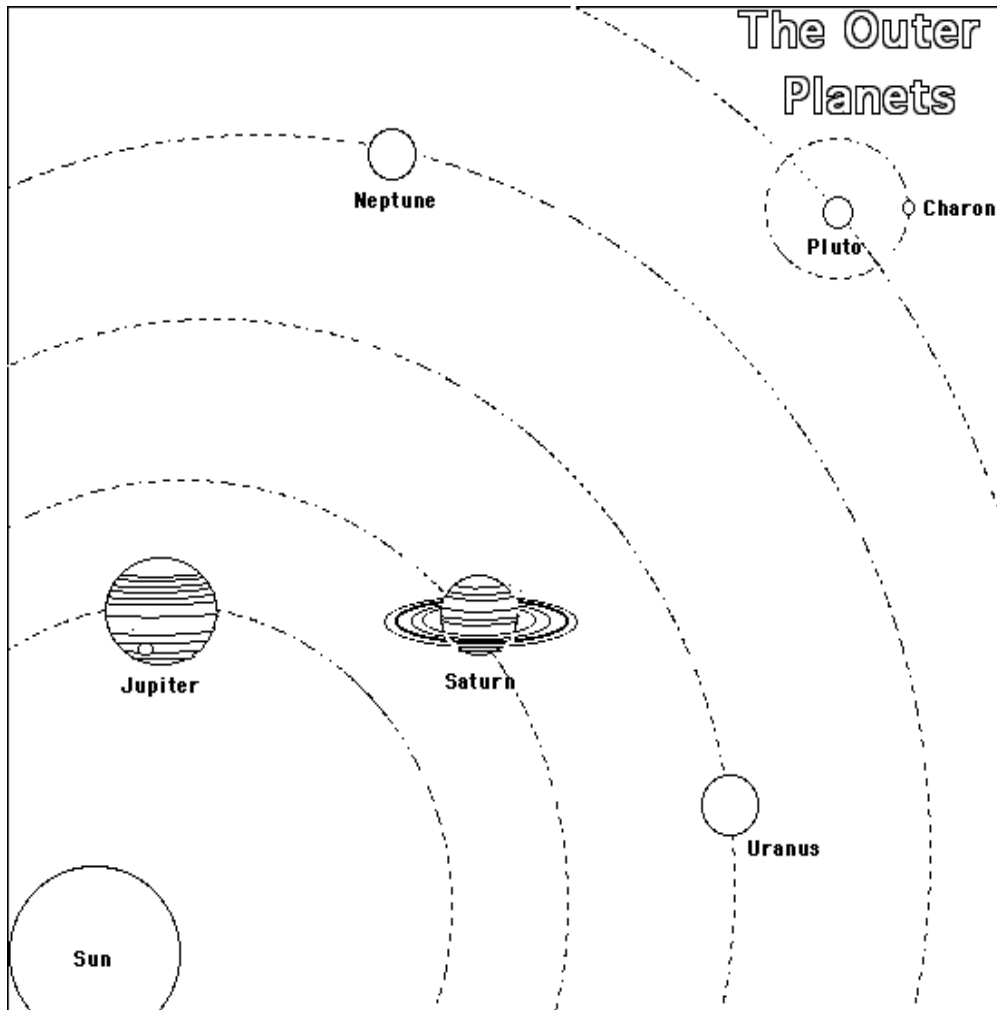

16) Think about and answer.

- What is at the centre of our Solar System?
- Which planet is the biggest?
- Which planet is called the "red planet"?
- What is the name of the group of objects that orbit the Sun between Mars and Jupiter?
- Are the inner planets made of rock or gas?

17) First, second, third, fourth, fifth ...

- a) The Earth is the planet from the Sun.
- b) Mercury is the planet from the Sun.
- c) Pluto is the planet from the Sun.
- d) Mars is the planet from the Sun.
- e) Jupiter is the planet from the Sun.
- f) Venus is the planet from the Sun.
- g) Saturn is the planet from the Sun.
- h) Neptune is the planet from the Sun.
- i) Uranus is the planet from the Sun.

18) Label the Aphelion-Perihelion.

Label the orbital diagram using the terms below.

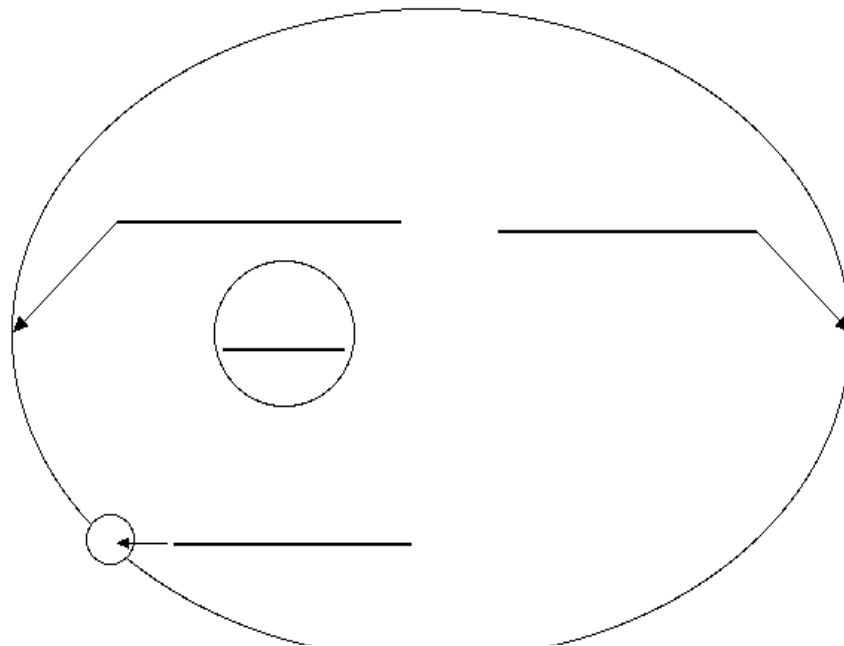

Aphelion - the point in an orbit that is farthest from the sun.

Perihelion - the point in an orbit that is closest to the sun.

Sun - the star in our Solar System.

Planet - a large celestial body that orbits a star.

19) Colour the Jupiter planet and answer.

Jupiter is the fifth planet from the Sun. It is a gas giant and the biggest planet in the Solar System. Jupiter has a thick atmosphere, four large moons, and dozens of smaller moons, and a barely-visible ring. The great red spot is an enormous storm.

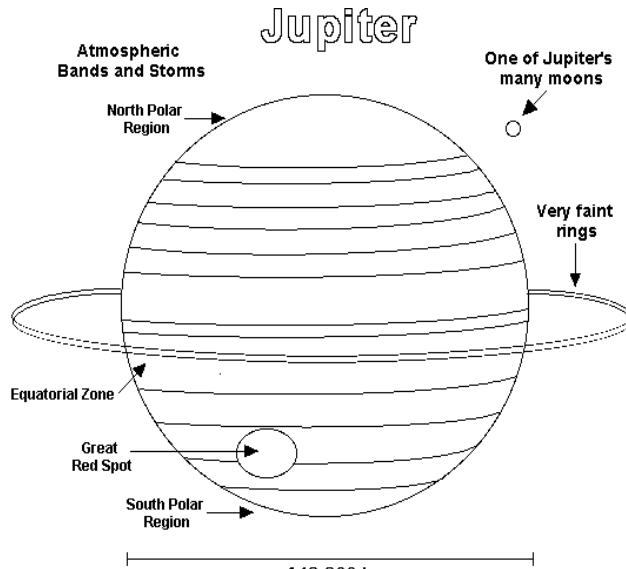

- Is Jupiter the biggest planet?
- Does Jupiter have a ring?
- Is Jupiter's atmosphere thick or thin?
- What is the red spot?

20) Colour the Saturn planet and answer.

Saturn is the sixth planet from the Sun. It is a gas giant and the second – biggest planet in our Solar System. It has beautiful rings that are made mostly of ice (and some rock). Saturn is made of hydrogen and helium gas. It has dozens of moons. Saturn is visible without using a telescope, but a low-power telescope is needed to see its rings.

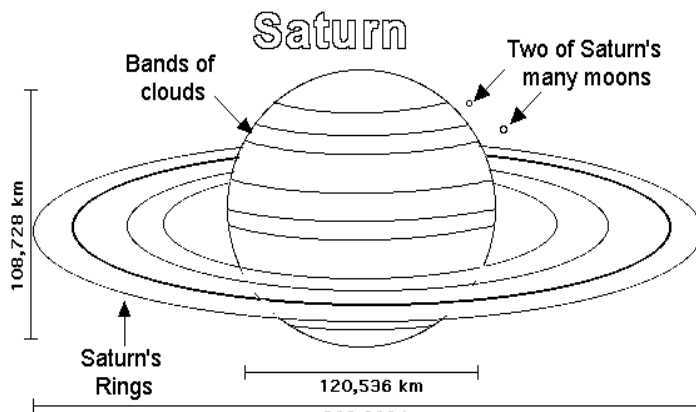

- Is Saturn rocky or gaseous?
- Is Saturn the biggest planet?
- How many moons are there in the Saturn planet?
- Can you see Saturn's rings using your eyes alone?

21) Space Word Chop.

conste	co	llation	gal
or	ipse	mete	black
orite	eor	zen	gra
vity	met	pla	ith
axy	mo	ecl	hole
net	aste	sate	met
roid	llite	on	bit

22) Space Word Search.

All words are positioned left to right, right to left, and diagonally.

F J C O N S T E L L A T I O N A V X N S J E G
R L P X V B V S C G I O L P Y Q R F E T U X T
K Q D L B Q G L R G K Y U O H Q K Y S O L S U
G B I E A D D A L V H K C I A Q N T P H K U W
K M O Y T N V T M O C U B M O Z K L I J R S Z
V Y P K A I E R U Q A L W C E A G A L A X Y G
Y P Y Z T X A T C N A Z G N A K O T C S D V Q
X P S Y A N P D P C G D I N E Q Y G E L X X Y
G X C K I Y L D K Y T T M R T F N E B H F E A
E Z U K I J D W E H E L P I Z X O W L E T R
D X R Q P V H I M C T D X L L Y R R W Z K I D
H N U H D O J O O E K Q Z E L S J W G S Z R D
W Q S W L E C H O R P G G V E L M J U N K O L
S I E E I N I R G G E N I T T J J E L O E E S
D X W K R W P M T K J T Y Y A W C T W O V T C
E O R B I T J R Y S B S S D S L Q H S M Q E B
W P Z W L V V X K J C C O A V H Z C H U G M B
A O O N A X L R Q H F Q F L E A K F V R Z O P

METEORITE	BLACK HOLE	METEOR	ORBIT
ECLIPSE	CONSTELLATION	GALAXY	MOON
ZENITH	GRAVITY	PLANET	
SATELLITE	ASTEROID	COMET	

23) Write the name planets in the boxes.

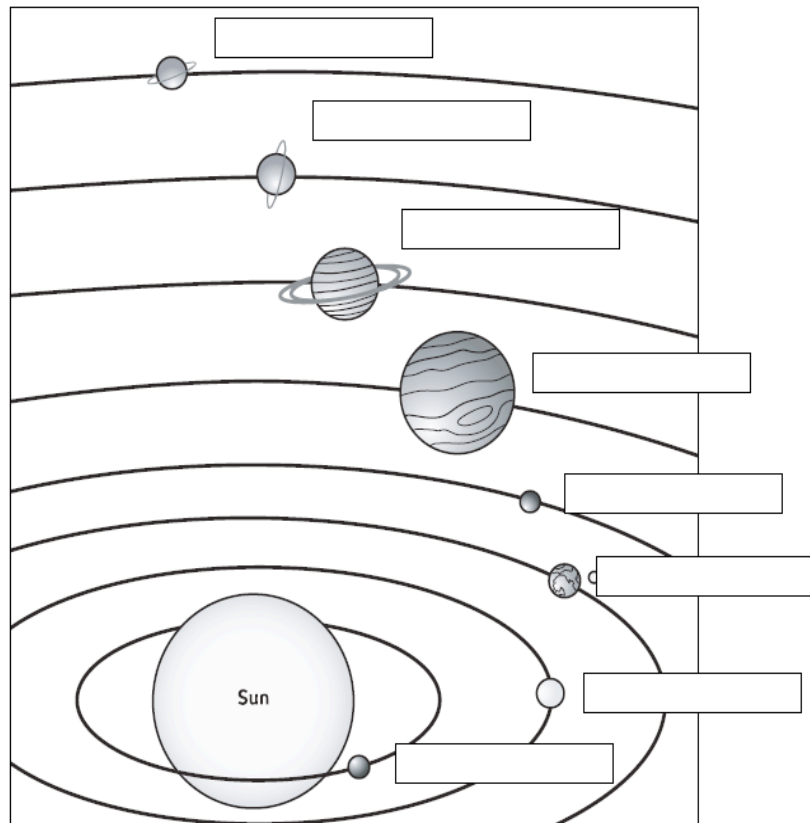

24) Draw a line from the planet to its name.

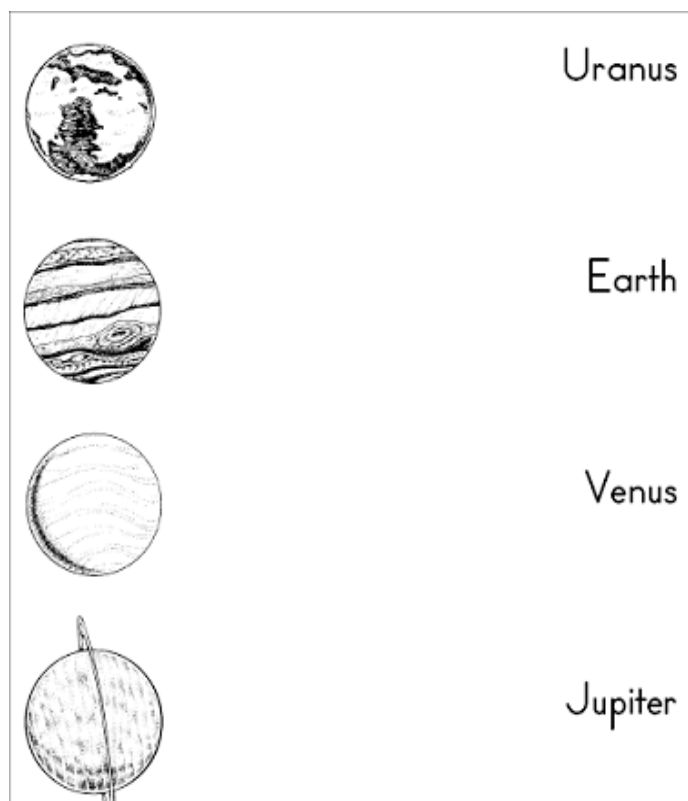

25) The planets are not all the same size.

Look at the planets, and then answer the questions below.

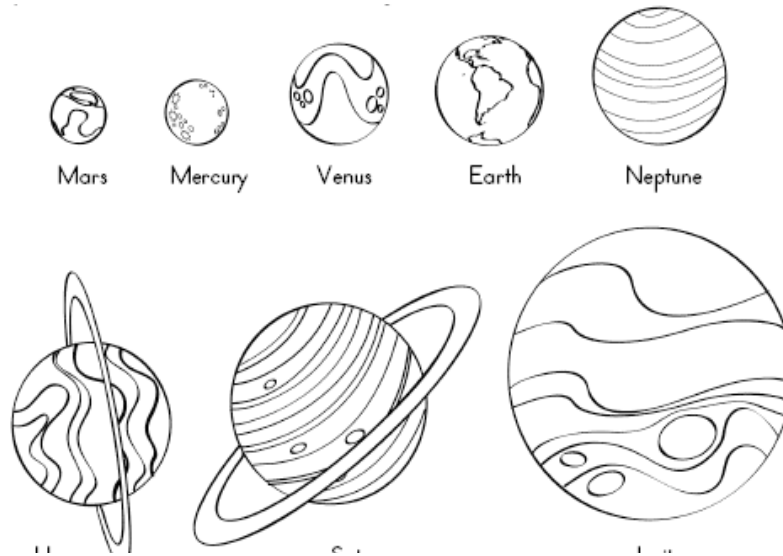

- Which planet is the smallest?
- Which planet is the biggest?
- Is Earth 5th or 6th biggest?
- Is Uranus bigger than Saturn?
- Which planet is almost the same size as Earth?

26) Find the words in the puzzle.

p	a	r	t	i	c	l	e	s
m	k	a	d	u	s	a	g	o
g	a	l	a	x	y	s	r	l
o	e	l	a	a	n	t	a	a
c	r	e	g	u	s	e	v	r
o	s	b	o	t	t	r	i	f
m	g	g	i	e	a	o	t	r
e	b	a	i	t	r	i	y	o
t	t	n	t	b	f	d	n	m
<hr/>								
comet	solar	asteroid	particles					
galaxy	star	gravity	orbit					

27) Solar System Game

http://www.nasa.gov/audience/forchildren/games/G_Solar_System_Game.html

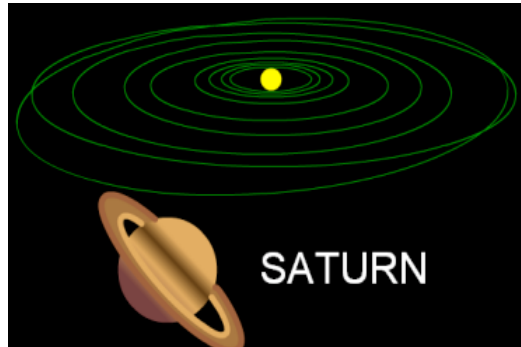

28) Play the Earth System Game

Sort the cards into the correct pile -- living things, air, water or land.



<http://www.cof.edu/ete/modules/k4/online/Eonline1.html>

29) How Old are You on Another Planet?

An Earth day is about 24 hours long. An Earth year is about 365 days long. Days and years on other planets are different. Some planets have very long days. Some have very short days. Some have very long years. Some have very short years. Type your birthday below. Click on a planet. You will see how old you would be if you had been born there!

<http://www.nasa.gov/audience/forchildren/games/age.html>

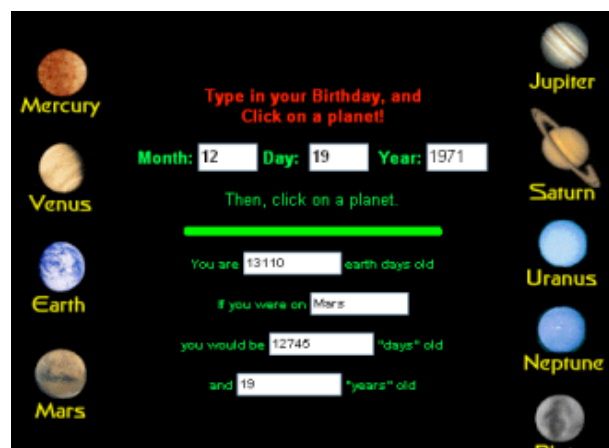

30) Connect the Stars!

Play connect the dots with the constellations!

<http://www.nasa.gov/audience/forchildren/games/connect.html>

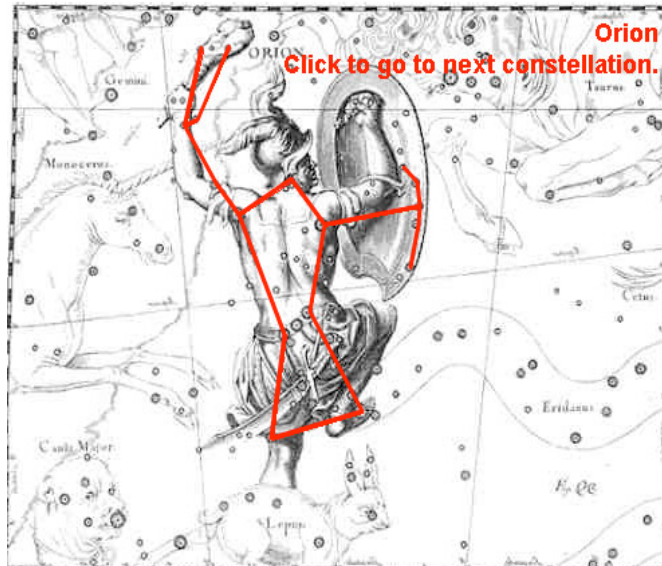

31) Solar System Trading Cards

Print out onto card stock or heavy paper. Cut out and fold in half along dotted line; glue or tape each card together.

http://amazing-space.stsci.edu/resources/print/activities/solsyst_tradecards_jr.pdf



32) Solar System Trading Cards – ON LINE.

Choose an object from our Solar System to name it and collect the card

<http://amazing-space.stsci.edu/resources/explorations/trading/game.htm>



33) Planet size comparison.

<http://www.sciencenetlinks.com/interactives/messenger/psc/PlanetSize.html>

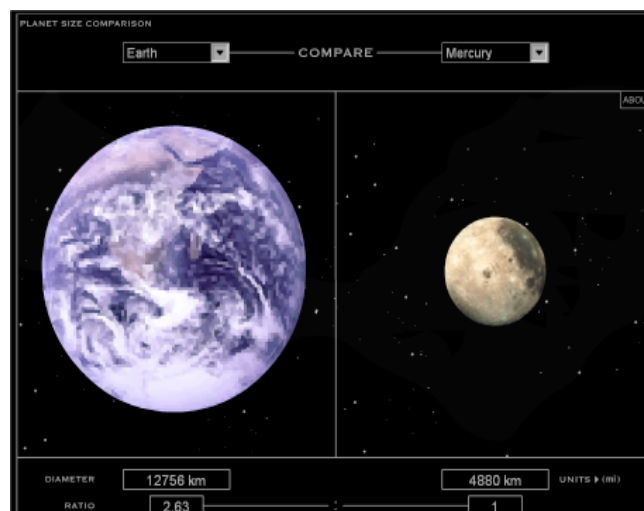

2. THE EARTH AND ITS MOVEMENTS

ACTIVITIES

1) Join with arrows.



Lunar Roving Vehicle



Apollo 11 - Flag



Lunar Eclipse



Footprint on the Moon



Earth from the Moon

4) Read the text and choose the right option:

Moon: A satellite that orbits a planet. Earth has one moon. Mars has two. Some planets have no moons (Mercury and Venus). Some planets have a dozens moons (Jupiter and Saturn). Our moon orbits the Earth in about one month.

- | | |
|-----------------------------------|--------------------------------------|
| 1. A moon orbits ... | 2. Do all planets have moons? |
| a) another moon | a) yes |
| b) a planet | b) no |
| c) a satellite | c) sometimes |
| 3. How many moons does Mars have? | 4. How many moons does Jupiter have? |
| a) one | a) one |
| b) two | b) two |
| c) a dozen | c) a dozen |

5) Remember and complete the paragraph. Use the words in the box.

Earth moons planets rings
Solar system Sun

The Solar system is very, very, big! The (1)is at the centre. There are nine (2)..... in the Solar system. They travel round the Sun. Four of the planets have got (3).....round them. And seven planets (for example, our planet, (4).....) have got (5).....

6) Match the words to the movements.

day	rotation	spring
summer		year
night	orbit	winter
spin		autumn

7) Rotation: days and nights. Complete the sentences.

The Earth rotates on its own axis. This movement creates the difference between day and night .

The Earth takeshours (one day) to complete one rotation on its axis. It rotates constantly without ever stopping. Rotation causes and..... On the half of the Earth facing the Sun, it is day. On the other half of the Earth facing away from the Sun, it is night. When it is night in Spain it is day in

8) Orbit: the seasons. Complete the sentences.

The Earth orbits the Sun. This movement causes the different **seasons**.

The Earth takes days andhours (one) to complete one orbit of the Sun. The amount of light and heat received from the Sun is not equal everywhere on Earth because the Earth spins on its **Its axis is tilted**, and this has an important effect.

This causes different climates in different areas of the world. It is also responsible for the changes in season during the year: **spring**,, and.....

The seasons happen at different times in the two hemispheres. When it is summer in the **Northern** Hemisphere, it is winter in the Hemisphere.

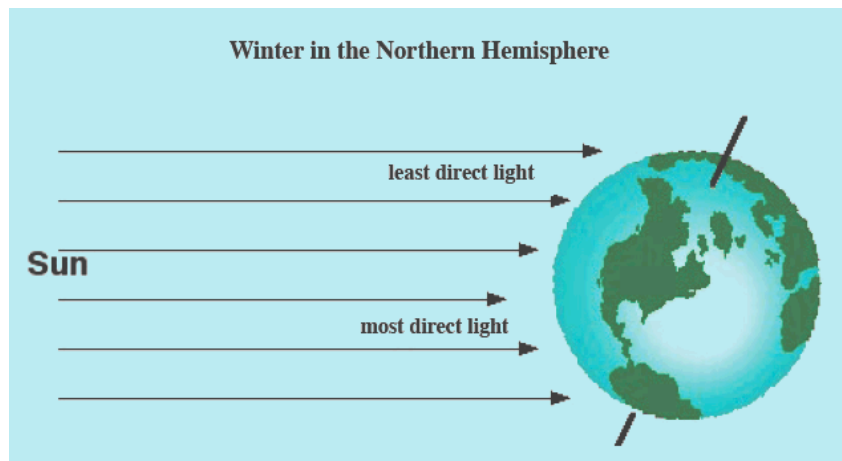

Axis of Rotation - An imaginary line going from the north pole to the south pole. The earth spins on this line.



9) Think about. ¿Summer or Winter?

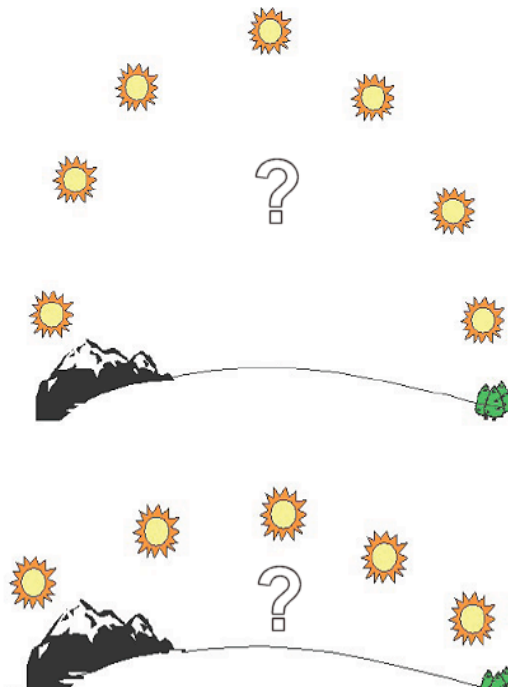

10) Use the data to make a line graph.

Day	Hours of daylight
Jan. 22	9
Feb. 22	10.5
Mar. 22	12
April 22	13
May 22	14.5
June 22	16
July 22	14.5
Aug. 22	13
Sept. 22	12
Oct. 22	10.5
Nov. 22	9
Dec. 22	8 hrs

a) What season has the most hours of daylight?

b) What causes the length of daylight to change?

Hours of Daylight

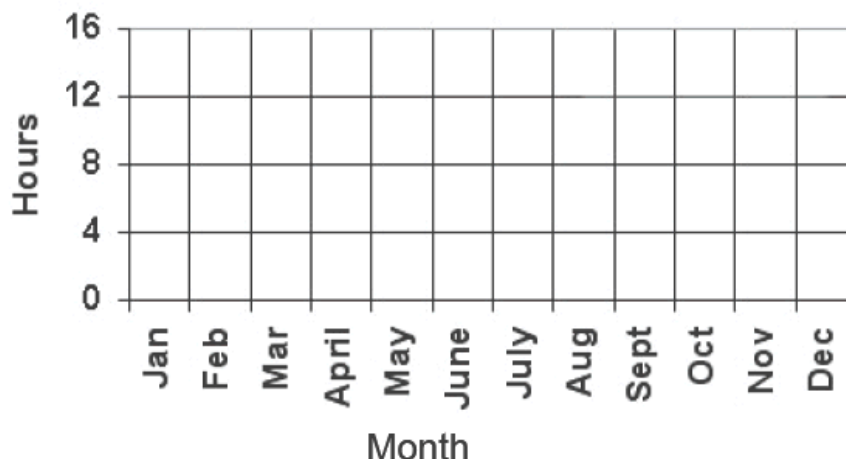

11) Lunar phases (Part One - easy). Join with arrows.

Phases of the Moon - The changes in the appearance of the moon's shape during a month.



New Moon. When the Moon is not illuminated.



Waning Moon. When the Moon is partially illuminated.



Waxing Moon. When the Moon is partially illuminated.



Half Moon. When the Moon is half illuminated.



Full Moon. When the Moon is totally illuminated.

a) Name the phases of the Moon.

b) Which phase of the Moon are we in now?

12) Lunar phases (Part two – difficult). Join with arrows.

What you see from Earth

The phases of the Moon

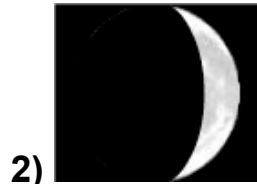
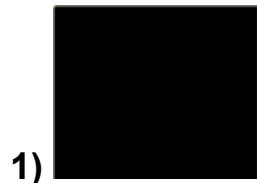

a) First Quarter

b) Third Quarter

c) Waning Crescent

d) New Moon

e) Waxing Crescent

f) Waning Gibbous

g) Full Moon

h) Waxing Gibbous

13) Lunar phases (Part Three – difficult). Join with arrows.

The Moon takes about one month (28 days) to orbit the Earth. This is called a **lunar month**.

- | | |
|---|--------------------|
| 1) days 1 and 29 | a) First Quarter |
| 2) 7 th - 8 th days | b) Third Quarter |
| 3) 16 th - 21 st days | c) Waning Crescent |
| 4) 24 th - 28 th | d) New Moon |
| 5) 15 th day | e) Waxing Crescent |
| 6) 9 th - 14 th days | f) Waning Gibbous |
| 7) 22 nd - 23 rd | g) Full Moon |
| 8) 2 nd -6 th days | h) Waxing Gibbous |

14) Label the Solar eclipse.

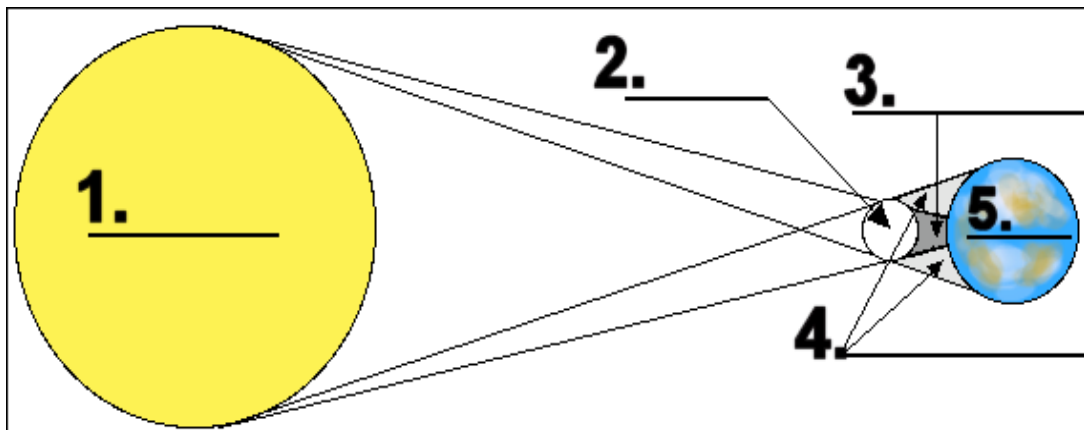

Earth: the planet on which we live.

Moon: the natural satellite of the Earth.

Penumbra: the area in which the shadow of an object (the moon on the Earth) is partial.

Sun: the star in our Solar System.

Umbra: the area in which the shadow of an object (the moon on the Earth) is total.

PENUMBRA: partial solar eclipse.
UMBRA: total solar eclipse.

15) Label the Lunar Eclipse.

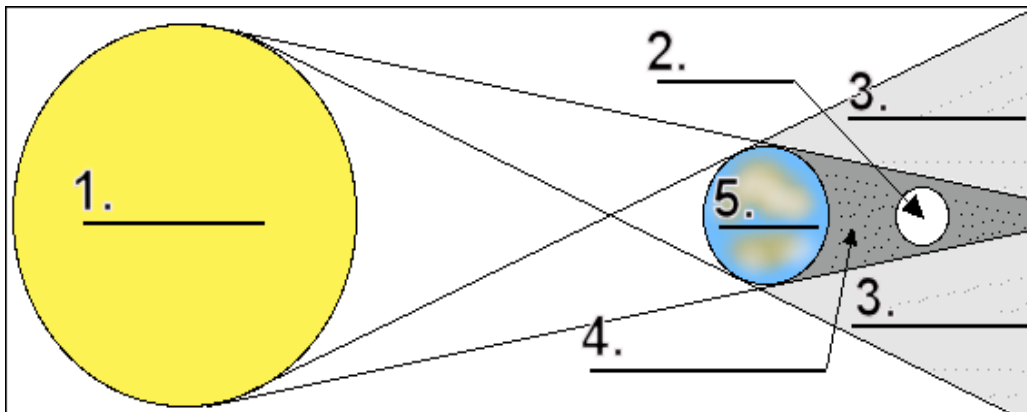

Penumbra: the area in which the shadow of an object (in this case, the Earth on the moon) is partial.

Umbra: the area in which the shadow of an object (in this case, the Earth on the moon) is total.

TOTAL LUNAR ECLIPSE: when the entire moon is in the Earth's umbra.

PARTIAL LUNAR ECLIPSE: when part of the moon is in the Earth's umbra.

16) The Earth (II).



- a) The Earth is covered with _____.
- b) The Earth is the _____ planet from the Sun.
- c) The length of one day on Earth is ____ hours.
- d) The Earth has ____ moon.

17) Remember.

The biggest planet is named(Colourred and yellow).

The smallest planet is named(Colour.....brown and gray).

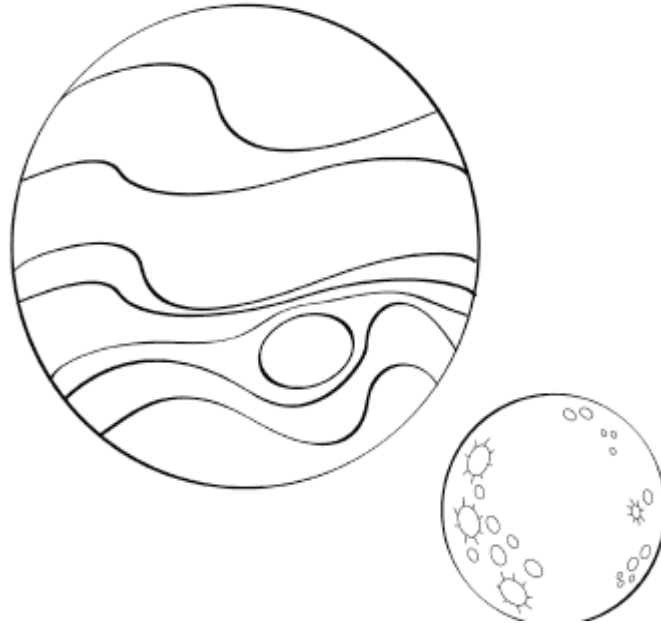

18) Learn about the lunar phases.

<http://aspire.cosmic-ray.org/>

Part 1

Your job is to determine which half of the moon is receives sunlight, and which half of the Earth receives sunlight.

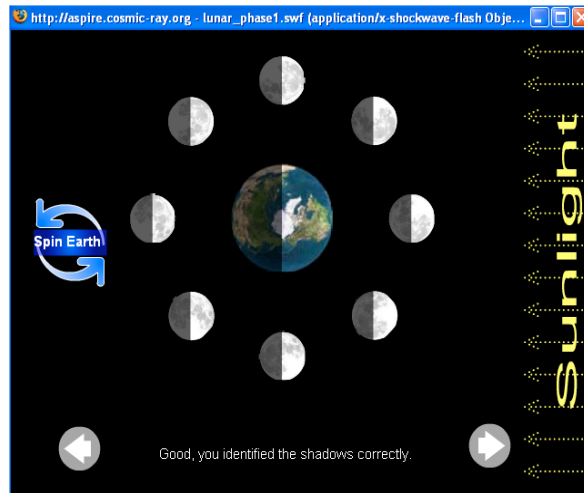

Part 2

Look at the moon when it is at position (a). It looks like half of the moon is light and half is dark. Find and click the picture that shows what the moon looks like in position (a). Your job is to continue through all the phases.

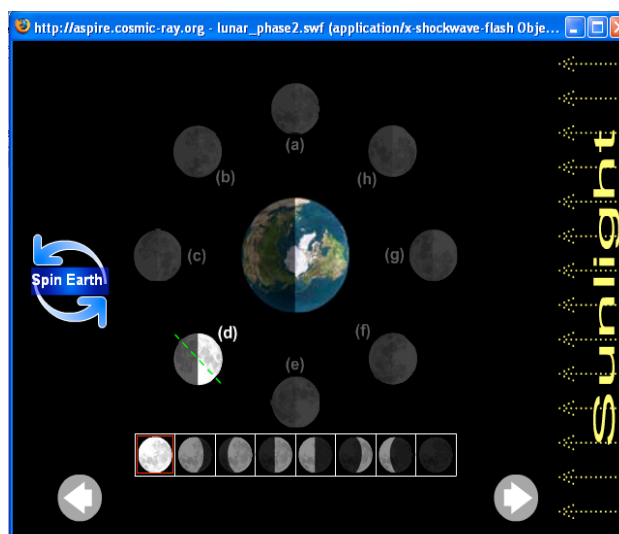

Part 3

You observe moon moving around the earth in it's orbit.

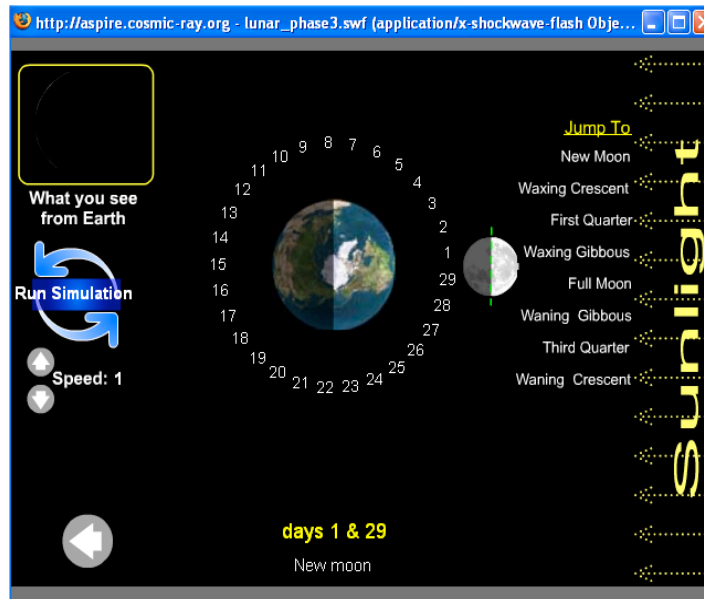

19) It's not the same. Nasa Kids' club.

http://www.nasa.gov/audience/forkids/kidsclub/flash/games/levelone/KC_Not_Same.html

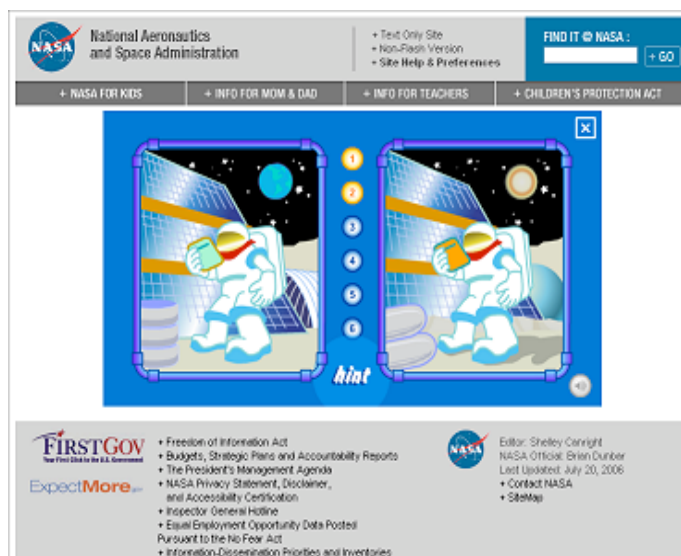

20) Go to the head of the Solar system. Nasa Kids' club. Help to the comet get to the Sun!

http://www.nasa.gov/audience/forkids/kidsclub/flash/games/levelfive/KC_Solar_System.html

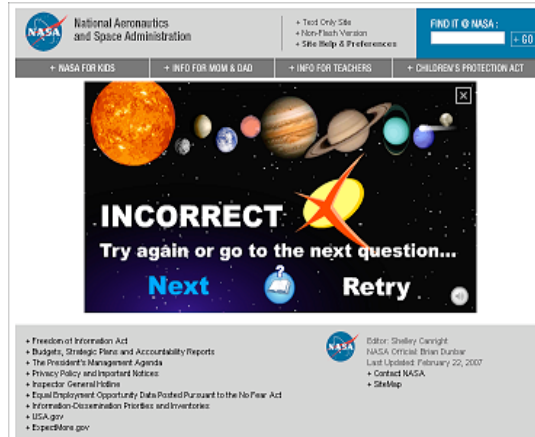

21) Solar eclipses video.

<http://www.teachersdomain.org/resources/ess05/sci/ess/eiu/eclipse/index.html>

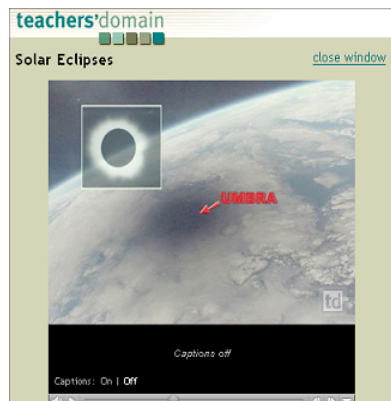

3. PROPERTIES OF MATTER

ACTIVITIES

1) Metric System: Centimetres.

The metric system is a way to measure. Using the metric system, we use centimetres to measure how long an object is.

Use a centimetre ruler to measure the following objects:

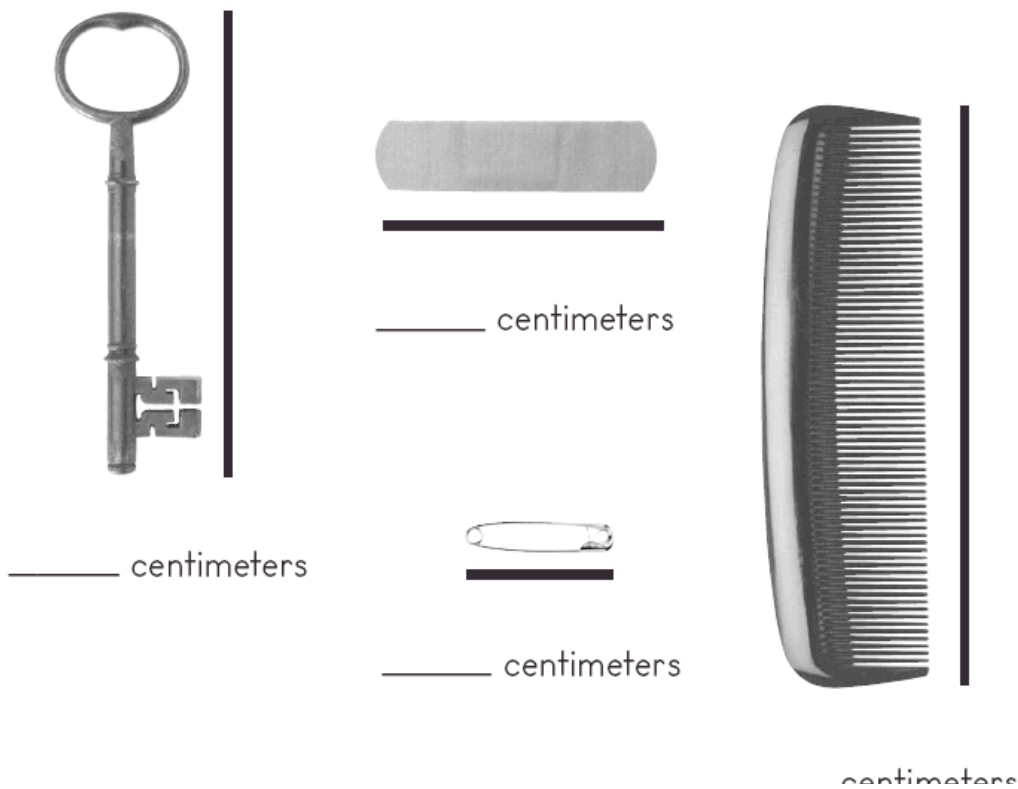

2) Centimetres.

The prefix centi- means a hundredth part. This means that 100 centimetres is the same as 1 meter.

$$100 \text{ centimetres} = 1 \text{ meter}$$

Use a tape measure to measure the heights of two classmates.

name

.....

.....metercentimetres

name

.....

.....metercentimetres

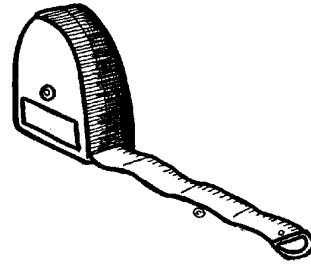

Tape measure

3) Meters and Centimetres.

Decide which unit of measurement to use for the following objects. Draw a line from the object on the left to the word on the right.



Meters



Centimetres



Meters



Centimetres



Meters



Centimetres

4) Height, Length, and Width.

The height of the chair is

The width of the chair is

The length of the chair is

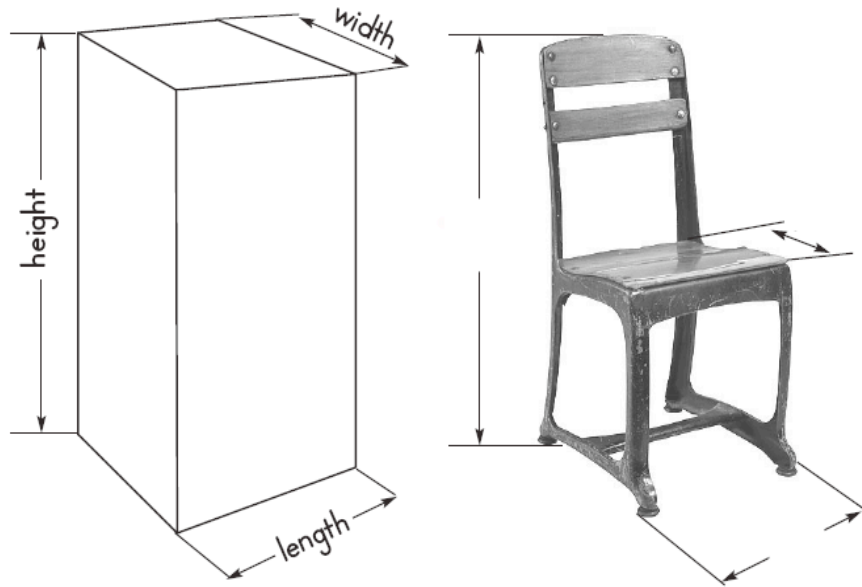

5) Conversion Practice. The ladder method.

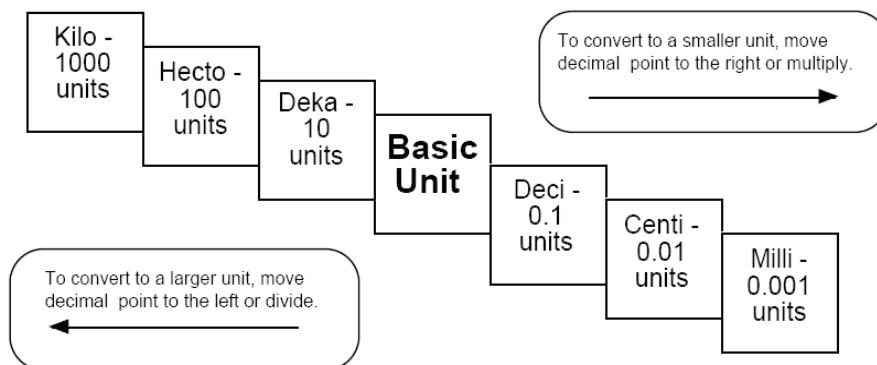
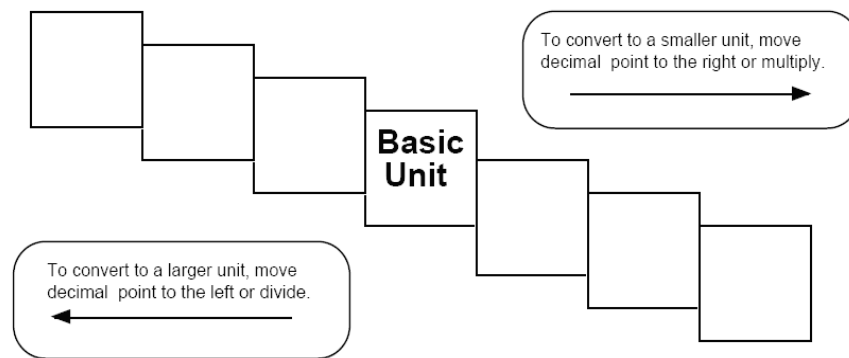

Try these conversions, using the ladder method.

1000 mg = _____ g

1 L = _____ mL

160 cm = _____ mm

14 km = _____ m

109 g = _____ kg

250 m = _____ km

Compare using <, >, or =.

56 cm ○ 6 m

7 g ○ 698 mg

6) Write the correct abbreviation for each metric unit.

1) Kilogram _____

4) Millilitre _____

7) Kilometre _____

2) Meter _____

5) Millimetre _____

8) Centimetre _____

3) Gram _____

6) Litter _____

9) Milligram _____

7) Try these conversions, using the ladder method.

1) 2000 mg = _____ g

6) 5 L = _____ mL

11) 16 cm = _____ mm

2) 104 km = _____ m

7) 198 g = _____ kg

12) 2500 m = _____ km

3) 480 cm = _____ m

8) 75 mL = _____ L

13) 65 g = _____ mg

4) 5.6 kg = _____ g

9) 50 cm = _____ m

14) 6.3 cm = _____ mm

5) 8 mm = _____ cm

10) 5.6 m = _____ cm

15) 120 mg = _____ g

Compare using <, >, or =.

16) 63 cm ○ 6 m

17) 5 g ○ 508 mg

18) 1,500 mL ○ 1.5 L

19) 536 cm ○ 53.6 dm

20) 43 mg ○ 5 g

21) 3.6 m ○ 36 cm

8) Convert each measure to mm.

1. 92 cm 1 mm = _____ mm

2. 61 cm = _____ mm

3. 51 cm = _____ mm

4. 2 mm 735 m = _____ mm

9) Convert each measure to cm.

1. 70 mm = _____ cm
2. 73 cm 10 mm = _____ cm
3. 946 m 6 km = _____ cm
4. 317 m = _____ cm

10) Convert each measure to m.

1. 7 km = _____ m
2. 79 m 3,300 cm = _____ m
3. 12 km = _____ m
4. 9,800 cm 872 m = _____ m

11) Convert each measure to km.

1. 8,000 m = _____ km
2. 38 km 8,000 m = _____ km
3. 12,000 m = _____ km
4. 3,000 m 243 km = _____ km

12) Convert each measure to cm and m.

1. 8,389 cm 9,000 mm = _____ m
_____ cm
2. 1,109 cm = _____ m _____ cm
3. 727 m 1,554 cm = _____ m _____
cm
4. 2,238 cm = _____ m _____ cm

13) Metric Weight. Convert each measure to mg.

1. 76 cg 3 mg = _____ mg
2. 83 cg = _____ mg
3. 9 cg 976 g = _____ mg
4. 32 cg = _____ mg

14) Metric Weight. Convert each measure to cg.

1. 90 mg 34 cg = _____ cg
2. 80 mg = _____ cg
3. 266 g 9 kg = _____ cg
4. 3 kg = _____ cg

15) Metric Weight. Convert each measure to g.

1. 8,000 mg = _____ g
2. 611 g 6,000 mg = _____ g
3. 696 g 8,000 mg = _____ g
4. 200 cg = _____ g

16) Metric Weight. Convert each measure to kg.

1. 3,000 g = _____ kg
2. 673 kg 9,000 g = _____ kg
3. 12,000 g = _____ kg
4. 567 kg 5,000 g = _____ kg

17) Metric Capacity. Convert each measure to mL.

1. 58 cl = _____ ml
2. 2 ml 75 cl = _____ ml
3. 21 cl = _____ ml
4. 3 ml 8 L = _____ ml

18) Metric Capacity. Convert each measure to cL.

1. 70 ml = _____ cl
2. 30 ml 6 cl = _____ cl
3. 1 kl 110 L = _____ cl
4. 80 ml = _____ cl

19) Metric Capacity. Convert each measure to L.

1. 6,100 cl 723 L = _____ L
2. 10,000 ml = _____ L
3. 10 kl = _____ L
4. 11 kl 11,000 ml = _____ L

20) Metric Capacity. Convert each measure to kL.

1. 12,000 L = _____ kl
2. 5,000 L 491 kl = _____ kl
3. 7,000 L = _____ kl
4. 2,000 L 70 kl = _____ kl

21) Join with arrows.

Mass

force of attraction between objects

Volume or Capacity

amount of matter

Weight

amount of space

GAMES AND INTERACTIVES

22) The Meter (Video).

<http://www.metricamerica.com/SI-Metric/meter.wmv>

23) The Kilogram (Video).

<http://www.metricamerica.com/SI-Metric/kilogram.wmv>

24) The Litre (Video).

<http://www.metricamerica.com/SI-Metric/liter.wmv>